

Low Pitch & Flat Roof Soffit Ventilator

CODE **G827**

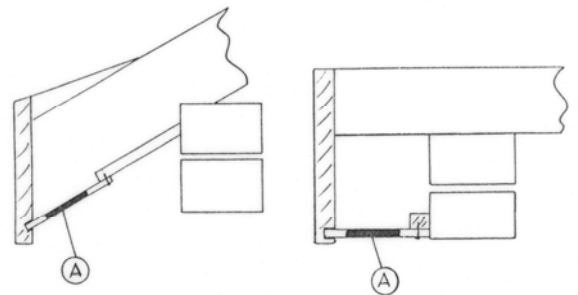
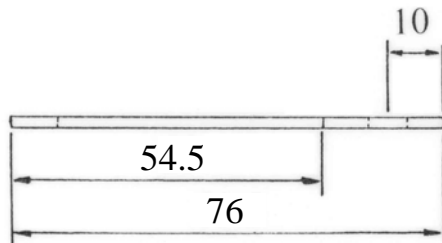
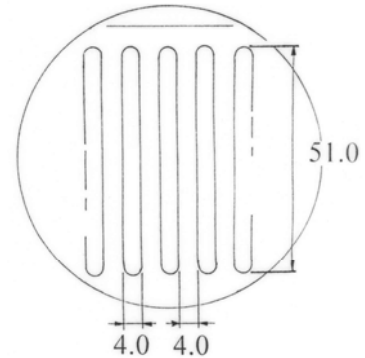
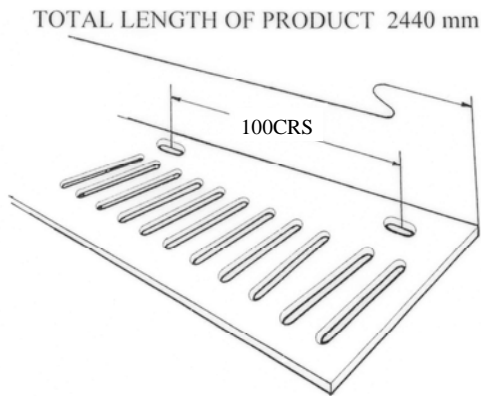

Description:

The G827 Flat Roof Soffit Ventilator is designed for a wide range of applications where the thick section soffit boards are used in the flat or sloping position and 25mm airflow is required.

The airflow passage consists of evenly spaced slots specifically sized to prohibit large insects gaining access but wide enough not to be blocked by debris, paint or water droplets (See BS5250 section 6).

Fitting Instructions:

The G827 Low Pitch & flat roof soffit ventilator (A) should be inserted into the rebated fascia board and then pushed up and securely screwed to either the soffit board or brick course as normal as shown.

Use in conjunction with other products from the Manthorpe range to provide a complete roof ventilation system.

COLOURS	Brown, White
PACKING DETAILS	Packed in 10's in poly sleeve.
WEIGHT	6.4kg per pack
MATERIAL	UPVC
MANUFACTURING PROCESS	Extrusion
FREE AIRFLOW	25,000mm ² /M equivalent to a continuous gap of 25mm

References:

BRE: DIGEST 262/270
 BSI: BS5250
 DOE: Building Regs F2
 NHBC: Good Practice Guide
 NHBC: Standards 7.2

MANTHORPE BUILDING PRODUCTS LTD
 MANTHORPE HOUSE
 BRITAIN DRIVE
 CODNOR GATE BUSINESS PARK
 RIPLEY
 DERBYSHIRE DE5 3ND

TEL: 01773 514 200
 FAX: 01773 514 262
 EMAIL: sales@manthorpe.co.uk
 WEB: www.manthorpe.co.uk

DRN B.H. Date 09.07.10

of continuous development of its product range and reserves the right to amend the specification without notice.

DRG No

MBP 8005

Issue

B