

3 Section Loft Ladder

CODE GL257

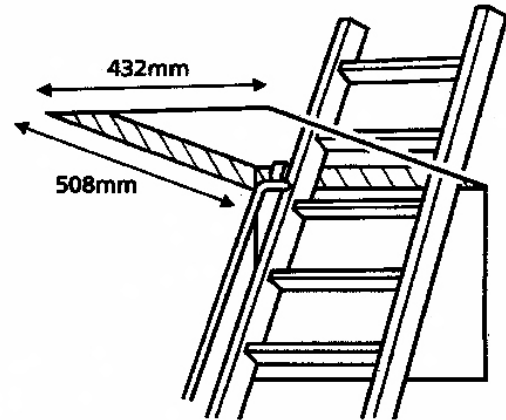
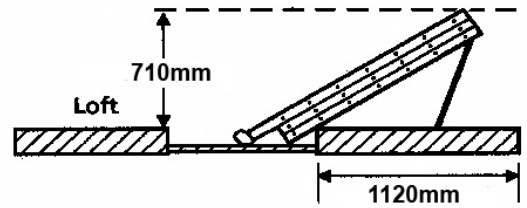
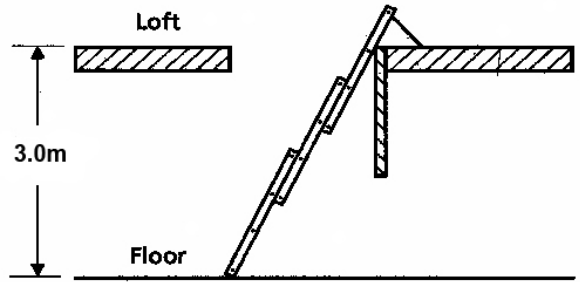
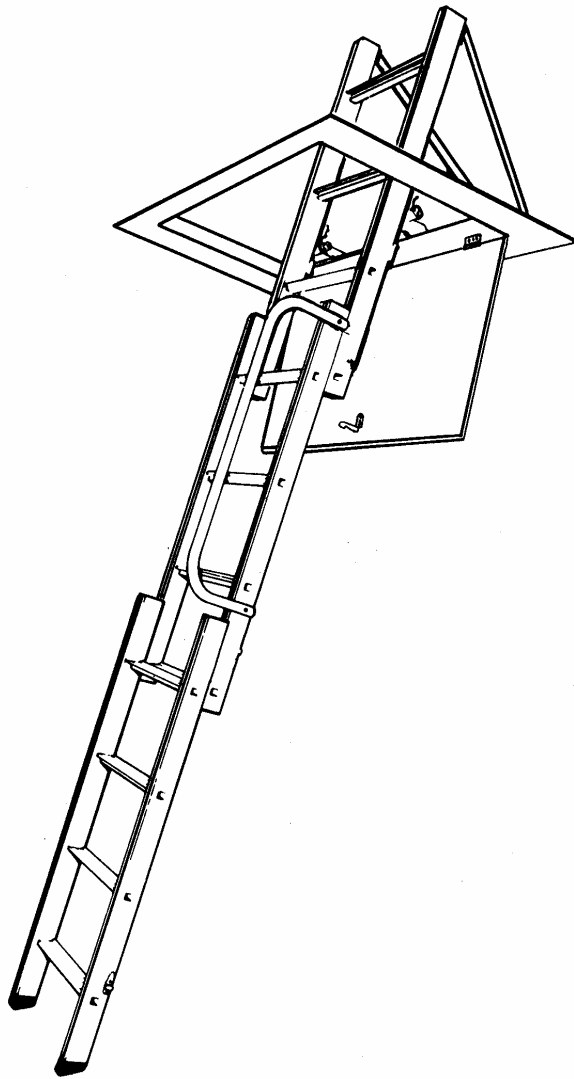

Description:

This 3 Section Loft Ladder provides an effective solution to loft access when combined with a GL250 loft access door. The robust three sections, aluminium constructed unit is compact, lightweight and easy to fit.

Feature include: -

- Metal safety catch which prevents premature drop during smooth sliding ladder operation.
- Deep non slip Treads.
- Hand rail for extra safety.
- Rubber feet for extra stability.

A complete fitting accessory pack and fitting instructions are supplied with each ladder, including operating pole.

PACKING DETAILS	Individually packaged in protective shrink film.
MATERIAL	Aluminum
WEIGHT	7Kg
MAX LOAD	150kG
STANDARDS	EN14975:2006

MANTHORPE BUILDING PRODUCTS LTD
 MANTHORPE HOUSE
 BRITTIAN DRIVE
 CODNOR GATE BUSINESS PARK
 RIPLEY
 DERBYSHIRE DE5 3ND

TEL: 01773 514 200
 FAX: 01773 514 262
 EMAIL: sales@manthorpe.co.uk
 WEB: www.manthorpe.co.uk

DRN M.C

Date 25.3.03

DRG No

Issue

The company maintains a policy of continuous development of its product range and reserves the right to amend the specification without notice.

MBP 8188

A