

Roll-Out Dry Hip System - Overview

CODE GDRH

Description

The Manthorpe Dry Hip is a mechanically fitted system which securely fixes the hip tiles on to a roof, protecting them from wind uplift and rain penetration.

The system provides 5000mm²/m ventilation to the roof void, through the vent roll the equivalent to a continuous 5mm gap.

Due to the nature in which the system is fitted, there is no need for mortar, making the job of fixing the hip quick, easy, and clean, as well as making it possible during frosts and other adverse weather conditions.

The system is compatible with most makes of concrete and clay hip tiles and most slate, flat concrete and profiled tiles. The system can be fitted to the hip of most roof pitches (pitches must be within tile manufacturers recommendations for the tile type being used)

A single box of Manthorpe Dry Hip provides all of the components required for a hip run approximately 6 metres in length (excluding the hip tiles).

The system is available in 3 different colours (Black, Dark Brown & Terracotta) and can be used in conjunction with Manthorpe's Roll-Out Dry Ridge System.

6 Metre Vent Roll (Code: GDRR-RR)

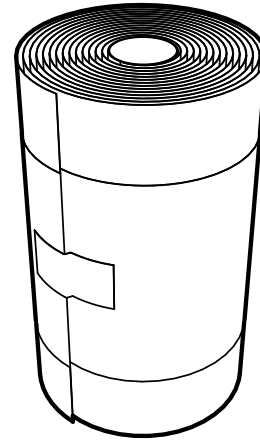

Ridge Union (Code: GDRR-RU)

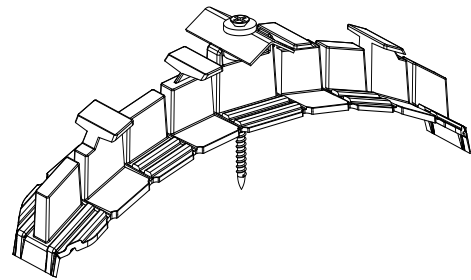

Features:

- Mechanical fixing system for the hip of a roof. Securely fixes the hip tiles, protecting the ridge from wind uplift and rain penetration without the need for mortar and pointing.
- One box supplies enough components for a 6m hip length.
- Compatible with most makes of concrete and clay hip tiles
- Can be fitted to the hip of most roof pitches (pitches must be within tile manufacturers recommendations for the tile type being used)
- The system is compatible with most slate, concrete flat and profiled tiles.
- Provides a 5000mm²/m ventilation into the roof space.
- Quick and easy to fix with no special tool requirements.
- Available in 3 different colours.
- No need for mortar, the system can be installed in all weathers.
- Can be used with Manthorpe's Roll-Out Dry Ridge System
- UV stabilised

1.1m Hip Tray (Code: GDRH-ST)

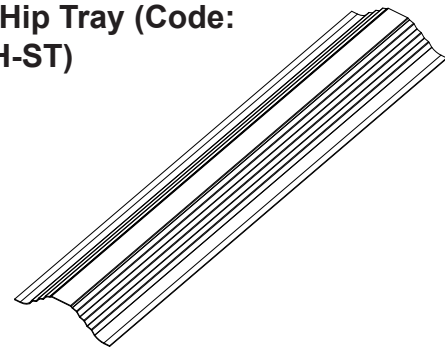

References

BSI: British Standard 5534:2003
 BSI: British Standard 6399-2:1997
 BSI: British Standard 5250:2002
 NHBC Standards Chapter 7.2

Dry Hip Pack - Packaging Details

GDRR-RR	x1 6 metre Vent Roll
GDRR-RU	x13 Ridge Unions
GDRH-ST	x6 1.1m Hip Trays

MANTHORPE BUILDING PRODUCTS LTD
 MANTHORPE HOUSE
 BRITAIN DRIVE
 CODNOR GATE BUSINESS PARK
 RIPLEY
 DERBYSHIRE DE5 3ND

TEL: 01773 514 200
 FAX: 01773 514 262
 EMAIL:
 sales@manthorpe.co.uk
 WEB
 www.manthorpe.co.uk

DRN M.R Date 20/08/08

The company maintains a policy of continuous development of its product range and reserves the right to amend the specification without notice.

DRG No

MBP 8277

Issue

C