

Roll-Out Dry Ridge System - Overview

CODE **GDRR**

Description

The Manthorpe Dry Ridge is a mechanically fitted system which securely fixes the ridge tiles on to a roof, protecting them from wind uplift and rain penetration. The system provides 5000mm²/m ventilation to the roof void, through the vent roll the equivalent to a continuous 5mm gap. Due to the nature in which the system is fitted, there is no need for mortar, making the job of fixing the ridge quick, easy, and clean, as well as making it possible during frosts and other adverse weather conditions. The system is compatible with most makes of concrete half round and angled ridge tiles and most slate, flat concrete and profiled tiles. The system can be fitted to the ridge of any duo pitch roof which has a pitch between 15 and 45 degrees. A single box of Manthorpe Dry Ridge provides all of the components required for a ridge run approximately 6 metres in length (excluding the ridge tiles). The system is available in 3 different colours (Black, Dark Brown & Terracotta) and can be used in conjunction with Manthorpe's Ridge End Caps and both their Linear and Standard Smart Verge systems.

Features:

- Mechanical fixing system for the ridge of a roof. Securely fixes the ridge tiles, protecting the ridge from wind uplift and rain penetration without the need for mortar and pointing.
- One box supplies enough components for a 6m ridge length.
- Compatible with most makes of concrete half round and angled ridge tiles.
- Can be used on roofs with a pitch of between 15 and 45 degrees.
- The system is compatible with most slate, concrete flat and profiled tiles.
- Provides a 5000mm²/m ventilation into the roof space.
- Quick and easy to fix with no special tool requirements.
- Available in 3 different colours.
- No need for mortar, the system can be installed in all weathers.
- Ridge ends can be finished off with Manthorpe's Ridge End Caps, available from their Smart Verge range.
- UV stabilised

References

BSI: British Standard 5534:2003
 BSI: British Standard 6399-2:1997
 NHBC Standards Chapter 7.2

6 Metre Vent Roll (Code: GDRR-RR)

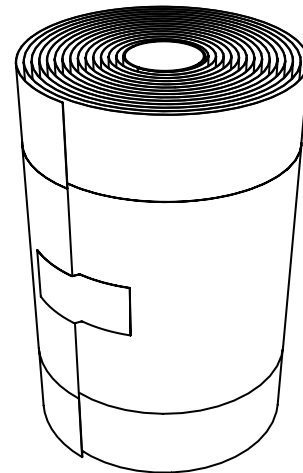

Ridge Union (Code: GDRR-RU)

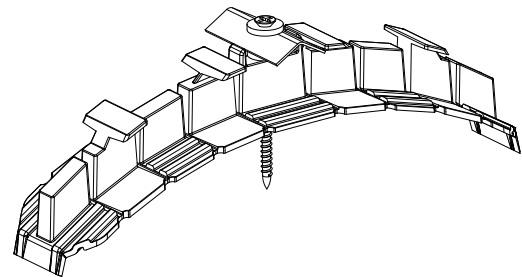

Batten Support Bracket (Code: GDRR-BS)

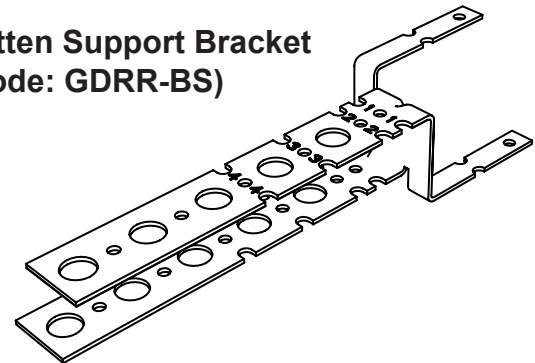

Dry Ridge Pack - Packaging Details

GDRR-RR	x1 6 metre Vent Roll
GDRR-RU	x13 Ridge Unions
GDRR-BS	x10 Batten Support Brackets.

MANTHORPE BUILDING PRODUCTS LTD
 MANTHORPE HOUSE
 BRITAIN DRIVE
 CODNOR GATE BUSINESS PARK
 RIPLEY
 DERBYSHIRE DE5 3ND

TEL: 01773 514 200
 FAX: 01773 514 262
 EMAIL:
 sales@manthorpe.co.uk
 WEB
 www.manthorpe.co.uk

DRN B.H Date 02/04/08

DRG No

Issue

The company maintains a policy of continuous development of its product range and reserves the right to amend the specification without notice.

MBP 8265

C