

Compatibility

The Manthorpe Roll-Out Dry Ridge System is designed to suit most makes of concrete half round ridge tiles and angled ridge tiles. The Dry Ridge System secures the ridge tiles to the roof, preventing wind uplift and rain penetration while providing a 5,000mm²/m free airflow into the roof space. The system is compatible with most makes of roof tile except Redland Delta and traditional deep profile Clay Pantiles.

Each kit contains sufficient parts to cover approx. **6 metres** of ridge. Additional round or angled ridge end caps from the Manthorpe Dry Verge System or the Manthorpe Linear Dry Verge System may be needed to finish off the ridge ends.

The following tables provide a guide for where the Batten Support Brackets should be bent. The numbers **1 - 4** refer to numbers on the Batten Support Bracket where the height of the batten can be adjusted.

Table 1. Angle Ridge Tile with Flat Tiles

Tile Height \ Pitch	15°	17½°	20°	22½°	25°	27½°	30°	32½°	35°	37½°	40°	42½°	45°
< 11 mm	-	-	2	2	1	1	1	1	1	1	1	-	-
11-20 mm	3	3	3	3	2	2	2	1	1	1	1	1	1
21-30 mm	-	4	4	3	3	3	3	3	3	2	1	1	1

Table 2. Half Round Ridge Tile with Flat Tiles

Tile Height \ Pitch	15°	17½°	20°	22½°	25°	27½°	30°	32½°	35°	37½°	40°	42½°	45°
< 11 mm	-	-	2	1	1	1	1	1	1	1	1	-	-
11-20 mm	3	3	3	2	2	1	1	1	1	1	1	1	1
21-30 mm	-	3	3	3	3	3	2	2	2	1	1	1	1

Table 3. Half Round Ridge Tile with Profiled Tiles

Tile Height \ Pitch	15°	17½°	20°	22½°	25°	27½°	30°	32½°	35°	37½°	40°	42½°	45°
21-30 mm	-	3	3	2	2	2	2	1	1	1	1	1	1
31-40 mm	-	3	3	3	3	2	2	2	2	1	1	1	1
41-50 mm	4	4	4	3	3	3	3	2	2	2	2	1	1
51-60 mm	-	4	4	4	4	3	3	3	3	2	2	2	2

Note 1: Standard 38mm x 25mm batten should be used.

Note 2: The 'Tile Height' refers to the maximum height of the profile of the tile.

The Complete System



6m Vent Roll
(Code: GDRR-RR)

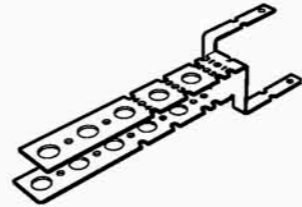

10 Batten Support Brackets
(Code: GDRR-BS)

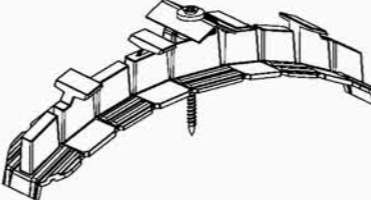

13 Ridge Unions
(Code: GDRR-RU)



Fixing Instructions
(Code: GDRR-RI)

Vent Roll Colours:
BL - Black
BR - Dark Brown
TR - Terracotta

The Manthorpe Roll-Out Dry Ridge System can be used in conjunction with The Manthorpe Dry Verge System or Linear Dry Verge System ridge end caps.



GDV-END-A



GDV-END-R

Other products from Manthorpe include Cavity Trays, Cavity Closer, Loft Doors, Linear Drainage, Access Panels, Roof Ventilation, Through Wall & Underfloor Ventilation, Joist Seals and Dry Roofing Products.



Manthorpe Building Products Limited

Manthorpe House, Brittain Drive, Codnor Gate Business Park, Ripley, Derbyshire DE5 3ND
T: (01773) 514200 F: (01773) 514262 E: sales@manthorpe.co.uk
W: <http://www.manthorpe.co.uk>



Roll-Out Dry Ridge System

Fixing Instructions

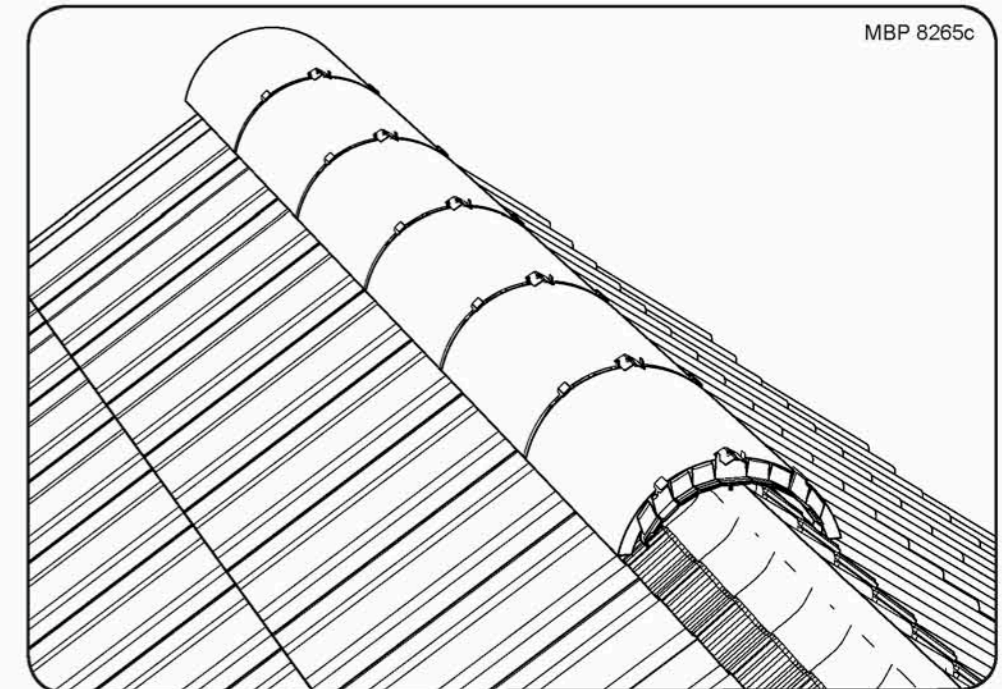

Ridge Details

Fig A. Assembly View of Dry Ridge Detail

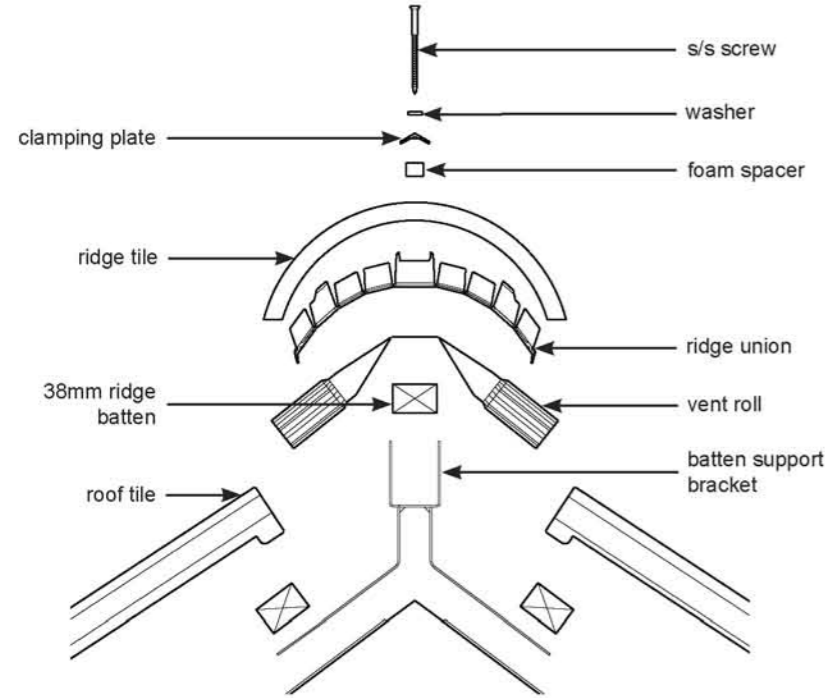
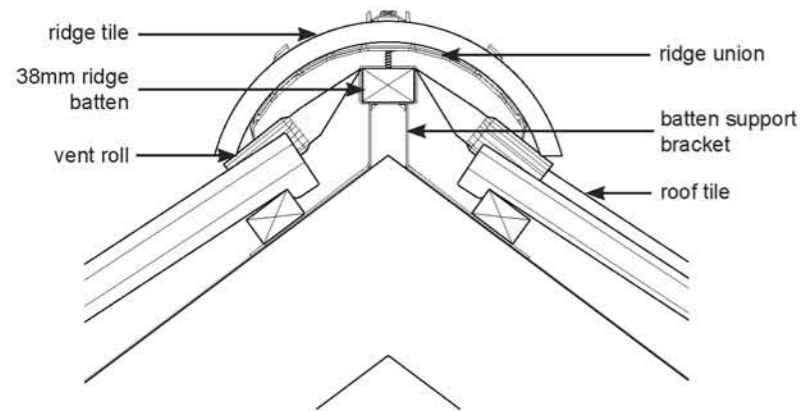
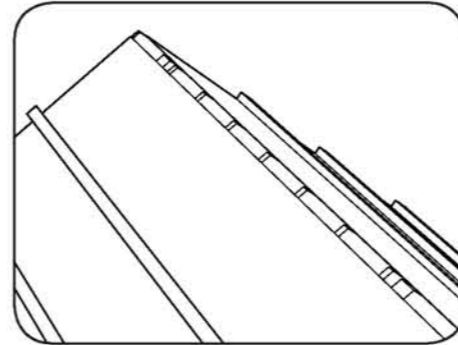

Fig B. Finished Dry Ridge Detail



Installation



1. Lay the roof underlay as normal. If ventilation is required through the ridge, underlay should be left short of the apex to provide a 5mm air gap either side.

For non ventilated ridge details, dress the underlay over the apex as normal.

Batten the roof as normal up to, but excluding, the top course tiling battens.

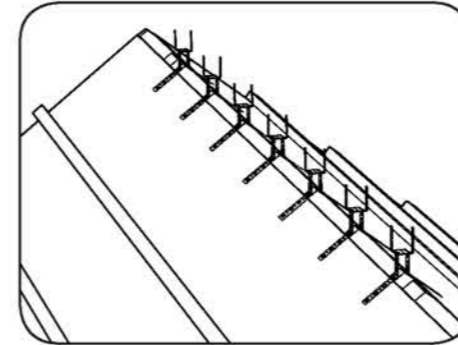

2. Adjust the height of the brackets by bending the bracket at the appropriate height (1-4) as indicated in tables 1-3 overleaf.

Using **30mm** stainless steel annular ring shanked nails, fix a Batten Support Bracket to the apex of every rafter. Nail each bracket to the rafters through two holes on each side.

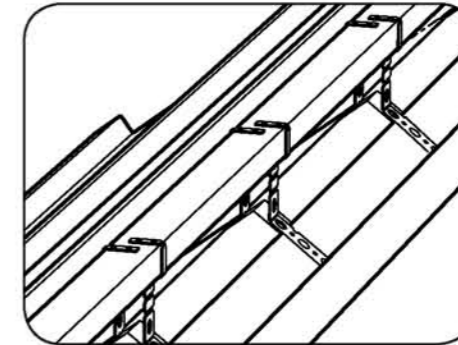

3. Lay a length of **38mm x 25mm** timber batten between the Support Brackets, then bend the two up-stands over the batten and nail in place.

If a Manthorpe Dry Verge Systems is used, ensure that the ridge batten overhangs the verge by **30mm** at each end.

Fix the top course tiling battens as normal.

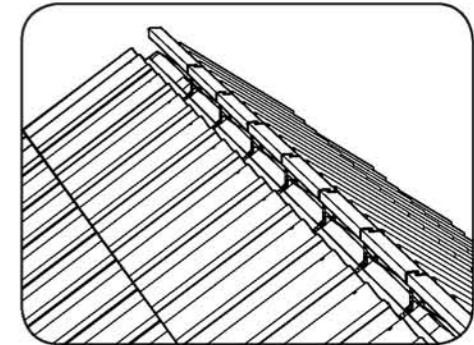

4. Tile the roof on both sides as normal.

If using the Manthorpe Dry Verge or Linear Dry Verge Systems, fix these at this stage.

Ensure the top course tiles are dry and free from dust before continuing.

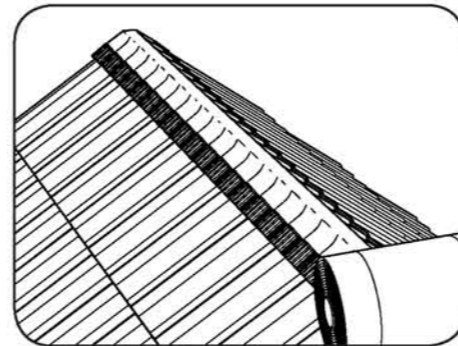

5. Roll out the Vent Roll along the entirety of the ridge.

Tack the roll at 1m intervals to the ridge batten using staples or felt nails.

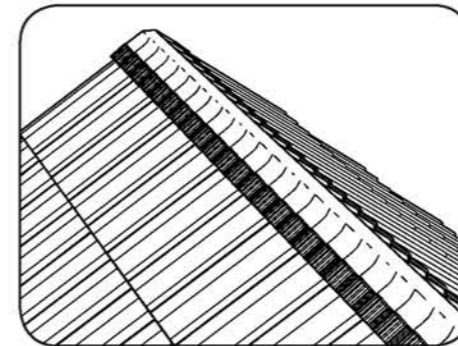

6. Remove the protective tape from the adhesive strip on the underside of the corrugated edge.

Push the entire length of the adhesive strip on to the tiles so that the corrugated strip moulds into the profile of the tiles.

Ensure that the Vent Roll is fully sealed along the entire ridge on both sides.

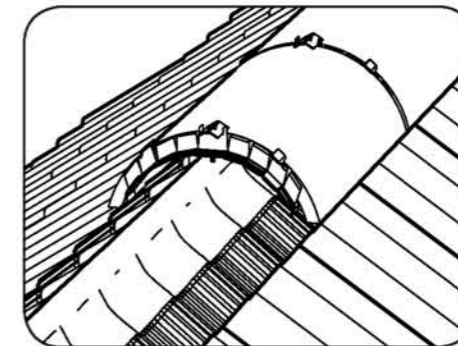

7. Lay the ridge tiles along the ridge, placing a Ridge Union between each pair of adjacent ridge tiles.

Secure the ridge tiles to the ridge batten by screwing the Clamping Plate over the ridge tile and into the ridge batten.

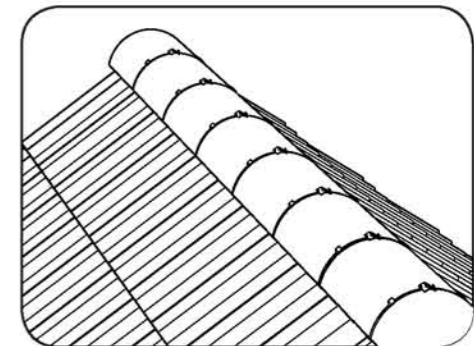

8. Repeat this process along the ridge until all ridge tiles have been laid.

If mortar is not being used at the ends of the ridge, a block-end ridge or Manthorpe Ridge End Cap should be used.