

Description

The Manthorpe G241M Multi Width Cavity Closer suits standard cavity widths between 50mm & 100mm. It provides an economical solution to cold bridging problems and can be cut to suit varying cavity widths.

G241M can be accurately cut by the user to suit various widths of cavity using the groove guides. Fig.1 shows groove guides and their corresponding widths.

G241M not only provides a thermal break to the cavity but also acts as an effective vertical DPC barrier.

G241M meets all building regulations and achieves the required U value at the reveal of door and window openings when the frames are fixed to allow a 15mm overlap into the cavity. This overlap can be reduced depending on the surrounding construction. For further fitting details on how to calculate this required overlap see BRE Information Paper IP 17.

For detailed fitting instructions see product information sheet MBP 8239.

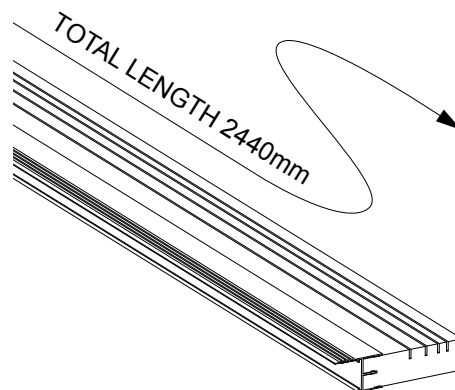
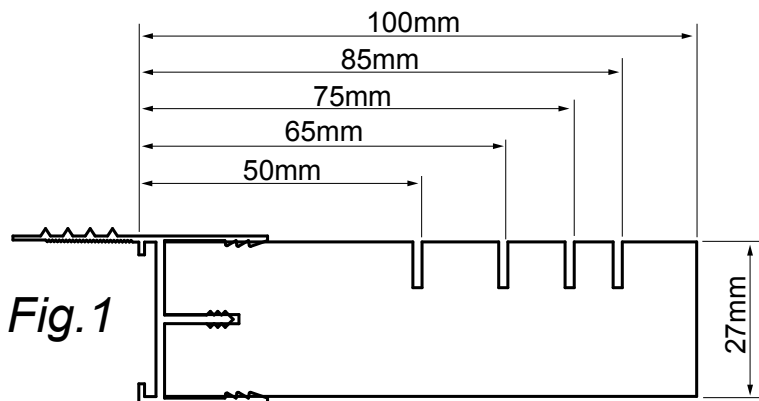

Specification	Extrusion	Insulation
Material	UPVC	CFC & HCFC Free. Extruded Polystyrene
Colours	White	Yellow
Manufacturing Process	Extrusion	Extrusion
K - Value		0.029 W/mk
Packing Details	6 Lengths per pack	
Weight Per Pack	6.8 Kg	

References	
BRE	DIGEST 262
BRE	Information Paper IP 17
BSI	BS5250
DOE	Building Regs L
NHBC	Good Practice
NHBC	Standards

MANTHORPE BUILDING PRODUCTS LTD
 MANTHORPE HOUSE
 BRITAIN DRIVE
 CODNOR GATE BUSINESS PARK
 RIPLEY
 DERBYSHIRE DE5 3ND

TEL: 01773 514 200
 FAX: 01773 514 262
 EMAIL:
 sales@manthorpe.co.uk
 WEB:
 www.manthorpe.co.uk

DRN P.S.

DATE 16.01.07

DRG NO

MBP 8246
PAGE (1 OF 1)

ISSUE

A

The company maintains a policy of continuous development of its product range and reserves the right to amend the specification without notice.