

Multi Width Thermal Cavity Closer

CODE G247M

Description

The Manthorpe G247M Multi Width Cavity Closer suits standard cavity widths between 50mm & 100mm. It provides an economical solution to cold bridging problems and can be cut to suit varying cavity widths.

G247M can be accurately cut by the user to suit various widths of cavity using the groove guides. Fig.1 shows groove guides and their corresponding widths.

G247M not only provides a thermal break to the cavity but also acts as an effective DPC barrier.

G247M meets all building regulations and achieves the required U value at the reveal of door and window openings when the frames are fixed to allow a 30mm overlap into the cavity.

For detailed fitting instructions see product information sheet MBP 8239.

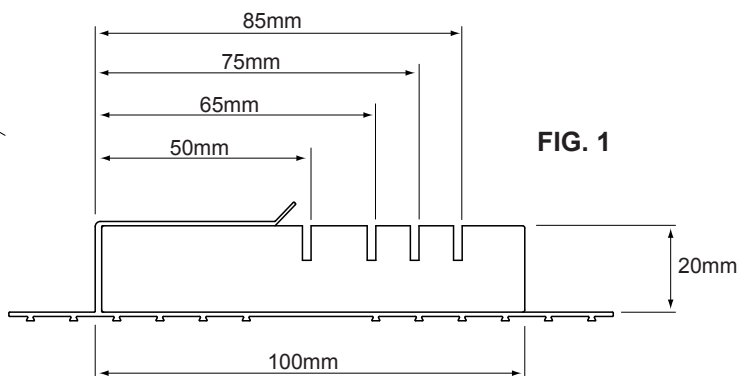
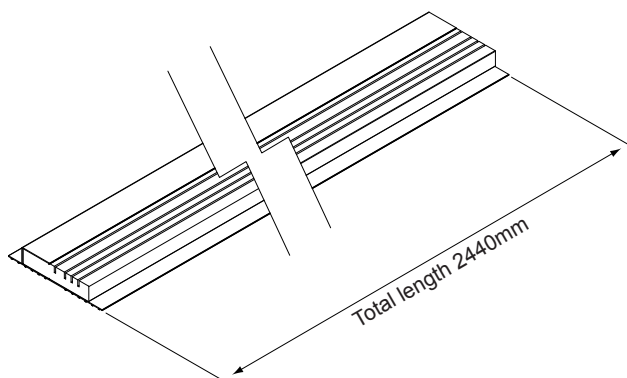

FIG. 1

Specification	Extrusion	Insulation
Material	UPVC	Superplus Polystyrene
Colours	White	Black
Manufacturing Process	Extrusion	
K - Value		0.030 W/mk
Packing Details	6 Lengths per pack	
Weight Per Pack	5.42 kg	

References	
BRE	DIGEST 262
BRE	Information Paper IP 1/06
BSI	BS5250
DOE	Building Regs L
NHBC	Good Practice
NHBC	Standards

MANTHORPE BUILDING PRODUCTS LTD
MANTHORPE HOUSE
BRITAIN DRIVE
CODNOR GATE BUSINESS PARK
RIPLEY
DERBYSHIRE DE5 3ND

TEL: 01773 514 200
FAX: 01773 514 262
EMAIL:
sales@manthorpe.co.uk
WEB:
www.manthorpe.co.uk

DRN M.R.

DATE 10.01.08

DRG NO

ISSUE

The company maintains a policy of continuous development of its product range and reserves the right to amend the specification without notice.

MBP 8246

B