

Rigid (T) Frame Former Assembly

CODE **G280/G282**

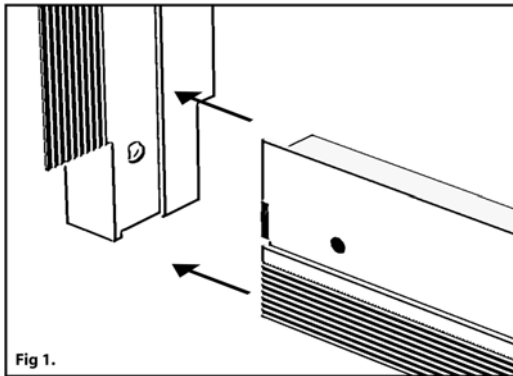

Fig 1.

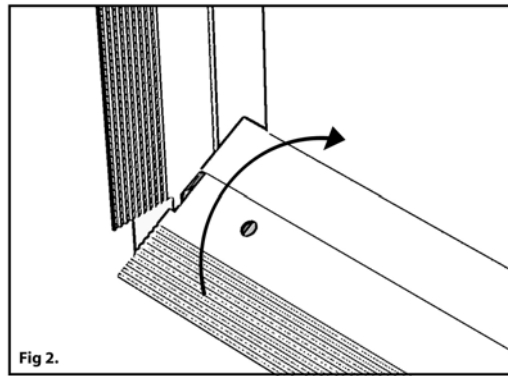

Fig 2.

Firstly get the cill pieces (these have both end caps assembled). Offer up to one of the jambs ensuring that the pre cut flanges are at the bottom (fig. 1). Push the end plug lug into the hole which has been pre drilled in the jamb length. Rotate the cill by 90° to the jamb to lock the cill in position (fig. 2).

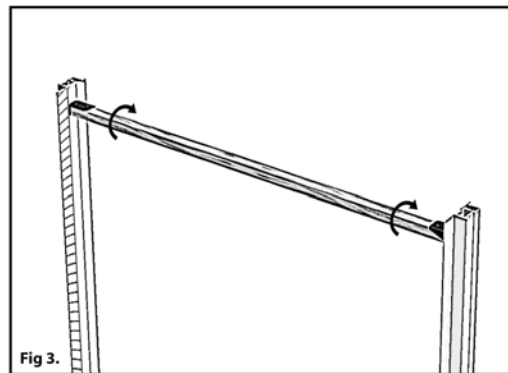

Fig 3.

Fit the horizontal top brace batten by inserting both lugs into the pre-drilled holes and rotating 90° to lock the brace in position (fig. 3).

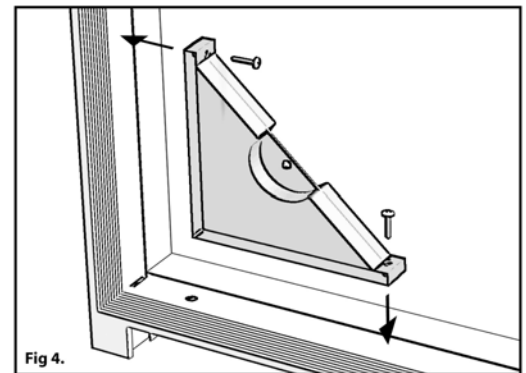

Fig 4.

Fit corner braces in all eight corners (as shown in fig. 5), using the self tapping screws provided.

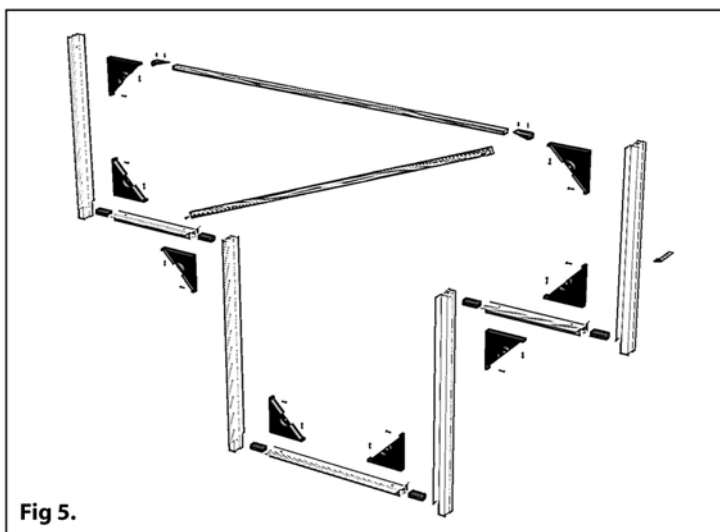

Fig 5.

Secure the diagonal batten brace at both ends to opposing corner braces using the plastic pins provided.

See MBP 8220 for further fitting instructions.