

### Rigid Frame Former

CODE **G280/G282**

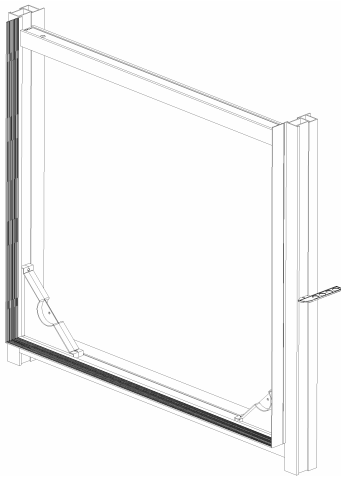

**G282** also available with single flange for rebated reveals.

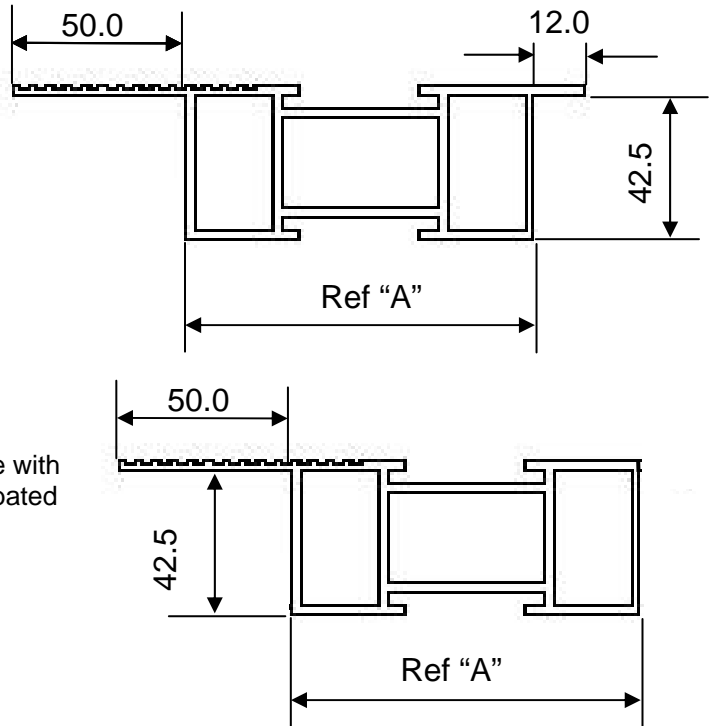

#### Description:

The Manthorpe G280/G282 Rigid Frame Former provides a simple time saving solution to cold bridging problems around window and door reveals. The rigid box design allows the cavity walling to be built up to the frame former without the need of manufacturing dummy window formers.

The Manthorpe G280/G282 Rigid Frame Former not only provides a thermal break to the cavity but also acts as an effective DPC barrier.

It is designed to meet building regulations and achieves the required U value at the reveal of door and window openings when the frames are fixed to allow a 30mm or larger overlap into the cavity.

For detailed fitting instructions see product information sheet MBP 8220 / 8219.

PRODUCT CODE		Ref "A" (Cavity Width)
G280/75FF	G282/75FF	75 + 0 - 2mm
G280/85FF	G282/85FF	85 + 0 - 2mm
G280/90FF	G282/90FF	90 + 0 - 2mm
G280/100FF	G282/100FF	100 + 0 - 2mm
G280/110FF	G282/110FF	110 + 0 - 2mm
G280/120FF	G282/120FF	120 + 0 - 2mm
G280/130FF	G282/130FF	130 + 0 - 2mm

#### References:

**Robust Details:** Limiting thermal bridging and air leakage

DOE: Building Regulations Part L  
 NHBC: Standards 1999  
 BRE: Information Paper IP17  
 BSI: BS5250

	EXTRUSION	FOAM
COLOUR/S	White	Grey
PACKING DETAILS	Secured to pallet	
MATERIAL	UPVC	Expanded Polystyrene
THERMAL CONDUCTIVITY		0.03 W/MK
MANUFACTURING PROCESS	Extrusion	Extrusion

MANTHORPE BUILDING PRODUCTS LTD  
 MANTHORPE HOUSE  
 BRITAIN DRIVE  
 CODNOR GATE BUSINESS PARK  
 RIPLEY  
 DERBYSHIRE DE5 3ND

TEL: 01773 514 200

FAX: 01773 514 262

EMAIL:  
[sales@manthorpe.co.uk](mailto:sales@manthorpe.co.uk)

DRN M.A

Date 05/07/04

The company maintains a policy of continuous development of its product range and reserves the right to amend the specification without notice.

DRG No

**MBP 8219**

Issue

**C**