

Fire Rated Cavity Closer

CODE **G249R**

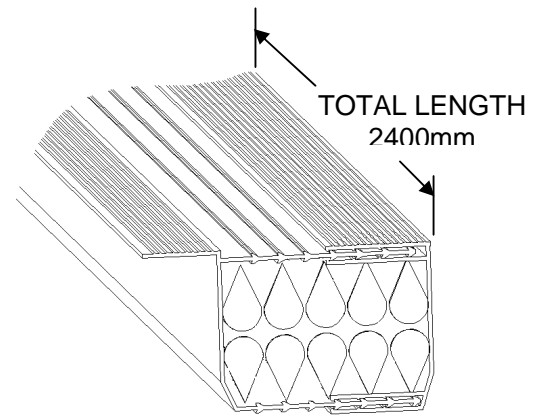
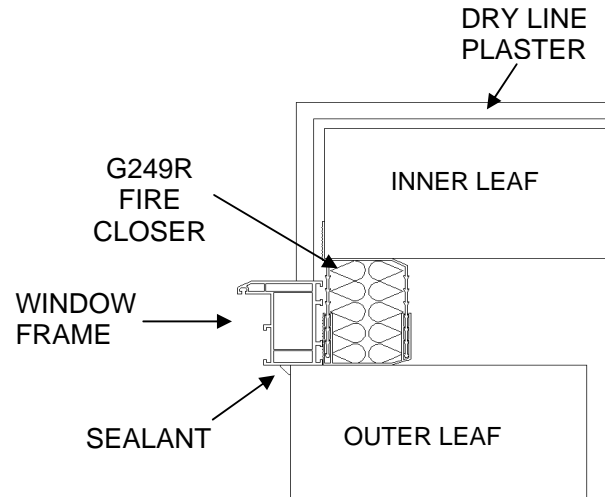
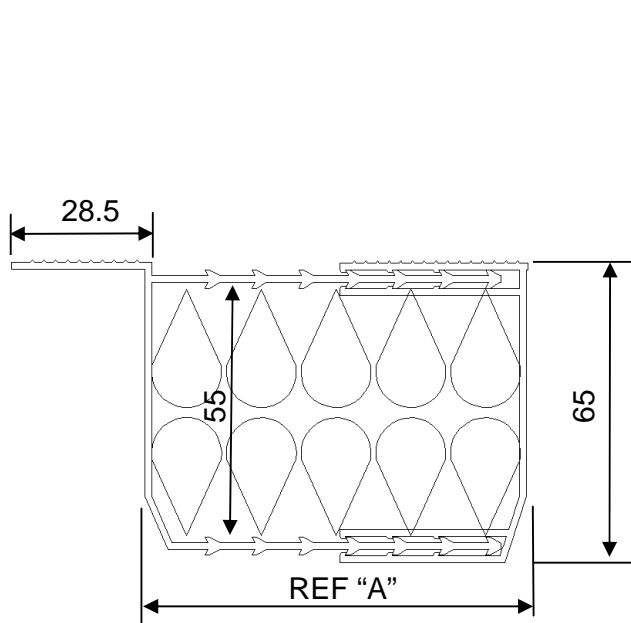

Description:

The Manthorpe G249R ½ Hour Fire Rated Cavity Closer is suitable for use in rebated openings where a fire barrier / fire stop is required to seal cavities around window and door reveals of a building.

In this construction the frame is positioned behind the outer leaf and is suitable for use in exposed categories up to and including very severe as defined in table 10 of BS5628 Part 3 which covers all exposure zones in the United Kingdom.

The unique compressible clip feature allows the product to expand within the cavity creating a continuous seal to any varying width. The enclosed box design incorporates a fibre insulating core which provides an economical solution to cold bridging acting as a thermal cavity closer, DPC and ½ hour fire barrier.

It is manufactured in four sizes that suit cavity widths varying from 50mm to 130mm in size. It can be easily installed either in new build or refurbishment situation with no special fixing requirements or tools. The Manthorpe G249R ½ Hour Fire Rated Cavity Closer has been designed to comply with Building Regs Part L and Scottish Technical Standards Part D.

PRODUCT CODE	DIMENSION REFERENCE "A"	TO FIT CAVITY WIDTH OF
G249R/50/70F	50 - 71.4+ / - 2mm	50-70MM
G249R/70/90F	70 - 91.4+ / - 2mm	70-90MM
G249R/90/110F	90 - 111.4+ / - 2mm	90-110MM
G249R/110/130F	110 - 131.4+ / - 2mm	110-130MM

PACKING DETAILS	3 lengths per pack
MATERIAL	PVCU
FIRE RATING	½ Hour Insulation & integrity
TEST CERTIFICATE	Warrington Fire Research: No 134212
MANUFACTURING PROCESS	Extrusion
COLOUR	White
K VALUE	0.039 W/mk

MANTHORPE BUILDING PRODUCTS LTD
 MANTHORPE HOUSE
 BRITAIN DRIVE
 CODNOR GATE BUSINESS PARK
 RIPLEY
 DERBYSHIRE DE5 3ND

TEL: 01773 514 200
 FAX: 01773 514 262
 EMAIL:
sales@manthorpe.co.uk
 WEB:
www.manthorpe.co.uk

DRN M.A

Date 16.3.04

The company maintains a policy of continuous development of its product range and reserves the right to amend the specification without notice.

DRG No

MBP 8203

Issue

C