

Fire Rated Cavity Closer

CODE **G249**

FIG 2

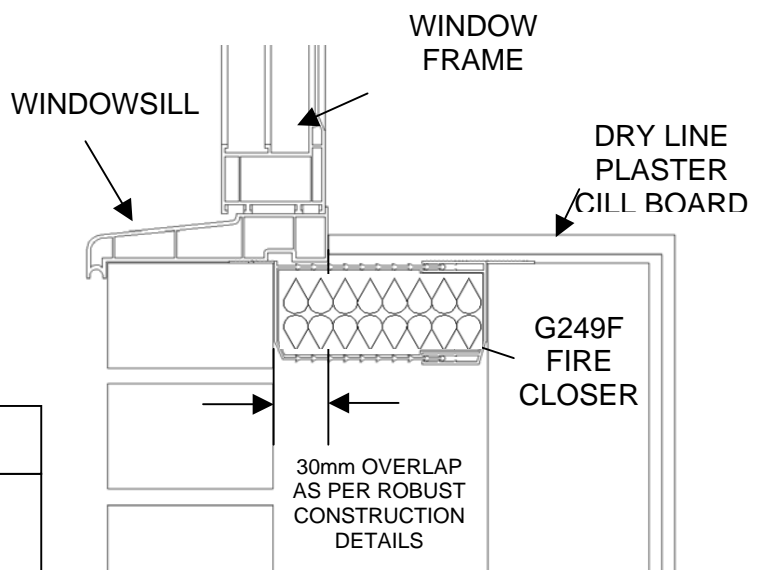
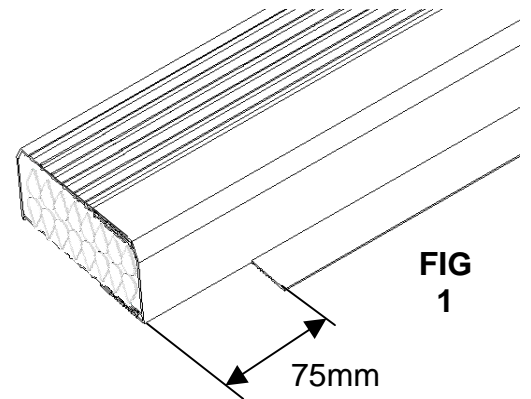
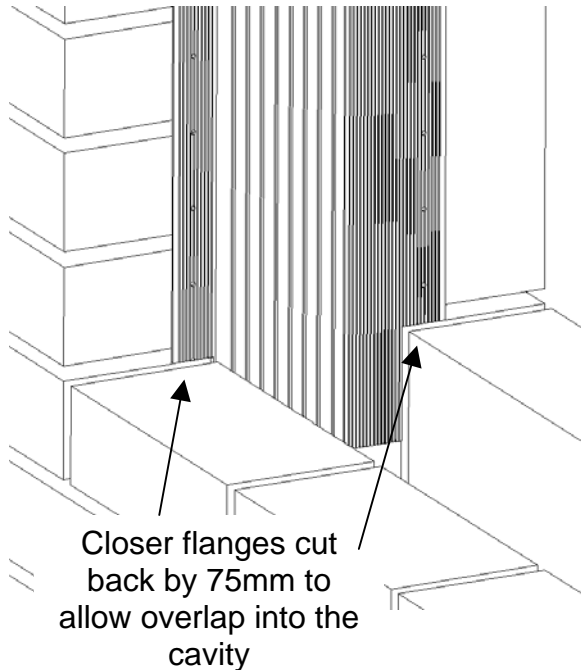

Fitting Instructions:

The Manthorpe G249F fire rated cavity closer is designed to be retrofitted into the cavity after the window / door reveal has been constructed.

- 1) Cut two jamb sections 75mm over the total length size. Trim back flanges from one end by 75mm (figure 1) to allow them to drop into the cavity below sill level. (figure 2)
- 2) Cut sill section to width of opening aperture and again push into cavity, ensuring any excess mortar is removed along fitment surface.

The installation is completed by the application of a weatherproof seal between the window frame and the outer leaf and dry lining or plastering at the internal reveal.

Note: - The cavity closer is non-load bearing and must not be used as replacement for traditional methods of fixing window and doorframes to the masonry.

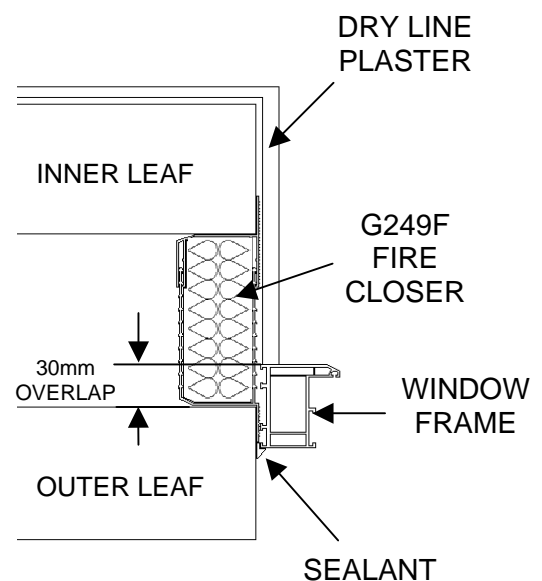

MANTHORPE BUILDING PRODUCTS LTD
MANTHORPE HOUSE
BRITAIN DRIVE
CODNOR GATE BUSINESS PARK
RIPLEY
DERBYSHIRE DE5 3ND

TEL: 01773 514 200
FAX: 01773 514 262
EMAIL: sales@manthorpe.co.uk
WEB: www.manthorpe.co.uk

DRN M.A

Date 16.3.04

DRG No

Issue

The company maintains a policy of continuous development of its product range and reserves the right to amend the specification without notice.

MBP 8200

A