

## Thermal Cavity Closer General Fitting

CODE **G240 / G242**

FIG 2

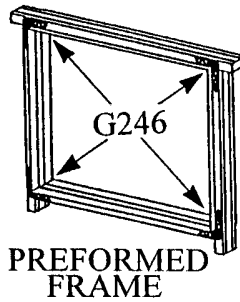

FIG 1

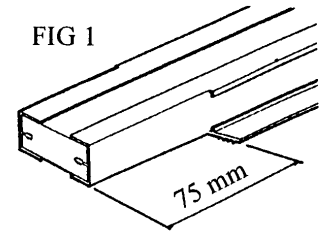

FIG 3

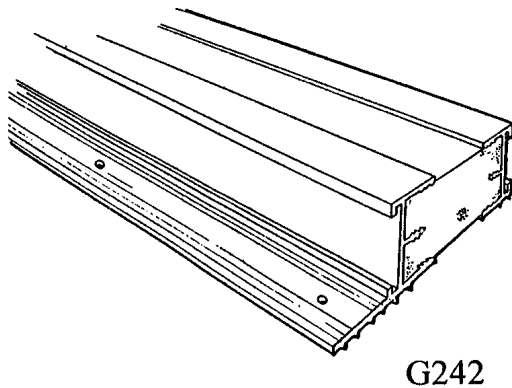
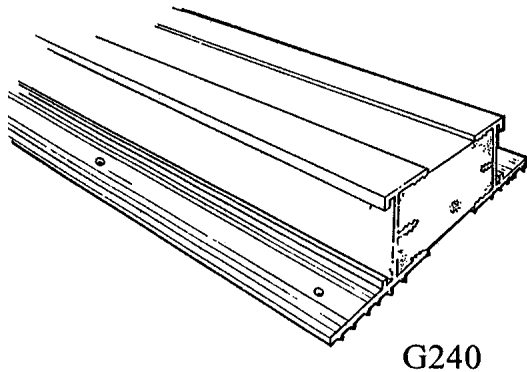
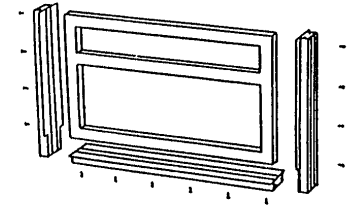
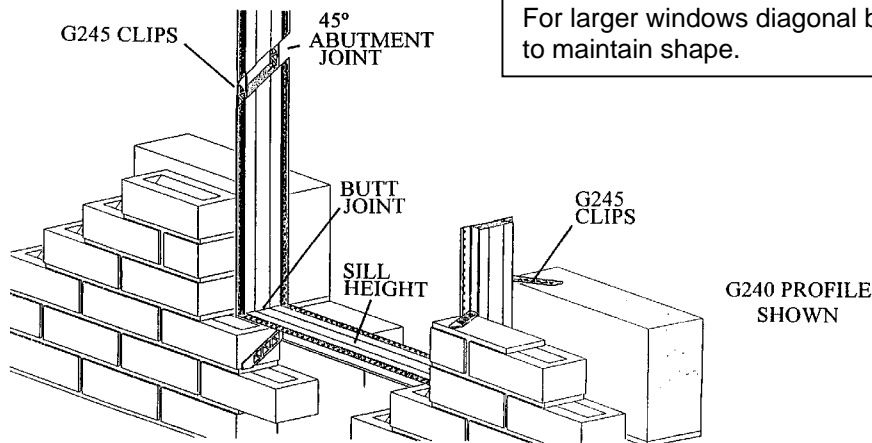

FIG 4



### Preparation:

Cut two jamb sections 75mm over size. Trim back lower flanges on jambs 75mm (figure 1) to allow them to drop into the cavity below sill level. Cut sill section to length. Short lengths of cavity closer can be joined together using fixing clips, ensuring butt joints slope down the cavity at 45 degrees to the outer leaf as shown (figure 4).

These sections can now be used in one of three ways:

- 1) Preformed into cavity frames (figure 2)
- 2) Used in individual lengths.
- 3) Nailed to frame or alternatively if PVC frames are being used self tapping screws (figure 3)

To form a cavity closer frame cut a top section 150mm over size with flanges trimmed back 75mm on both ends. Using eight right angle clips assemble corners as shown (figure 2). The top section can be removed and reused on completion of the opening.

For larger windows diagonal bracing may be required to maintain shape.

MANTHORPE BUILDING PRODUCTS LTD  
MANTHORPE HOUSE  
BRITAIN DRIVE  
CODNOR GATE BUSINESS PARK  
RIPLEY  
DERBYSHIRE DE5 3ND

TEL: 01773 514 200  
FAX: 01773 514 262  
EMAIL: [sales@manthorpe.co.uk](mailto:sales@manthorpe.co.uk)  
WEB: [www.manthorpe.co.uk](http://www.manthorpe.co.uk)

DRN M.L.W.O

Date 01.08.03

DRG No

**MBP 8088**

Issue

**A**

The company maintains a policy of continuous development of its product range and reserves the right to amend the specification without notice.